

DEUS RRC PVT. LTD.



*Leading manufacturer of SNT Radio Remote Control Systems &
other Crane Control Equipments.*

- Plot No.4319, G.I.D.C, Vatva, Phase IV, Ahmedabad - 382445, Tel: 079-25841148, E-mail:sales@sntrrc.com
- 120, Acharya Ind. Estate, Tejpal Compound, Andheri-kurla Road, Sakinaka, Mumbai-400 072
Tel. : +91 7506507534 / 9821092946 E-mail: mail@sntrrc.com

Technical Data

Body Material	Alluminium Die Cast (Powder Coated)
Mounting Position	Floor
Contact Material	Silver Cadmium
Cable Entries	2, 3/4" Conduit
Protection Degree	IP-55 Confirming to (IS/IEC-60529(2001)
Wire Connection	Screw Terminal
Current	10 A
No. Of Contacts	MAX 2
Rated voltage	500 V.A.C. Max



Switching Diagram

CWLS/2/SH/2		
CONTACT NO.	0	1
1	X	
2	X	

GA DRAWING

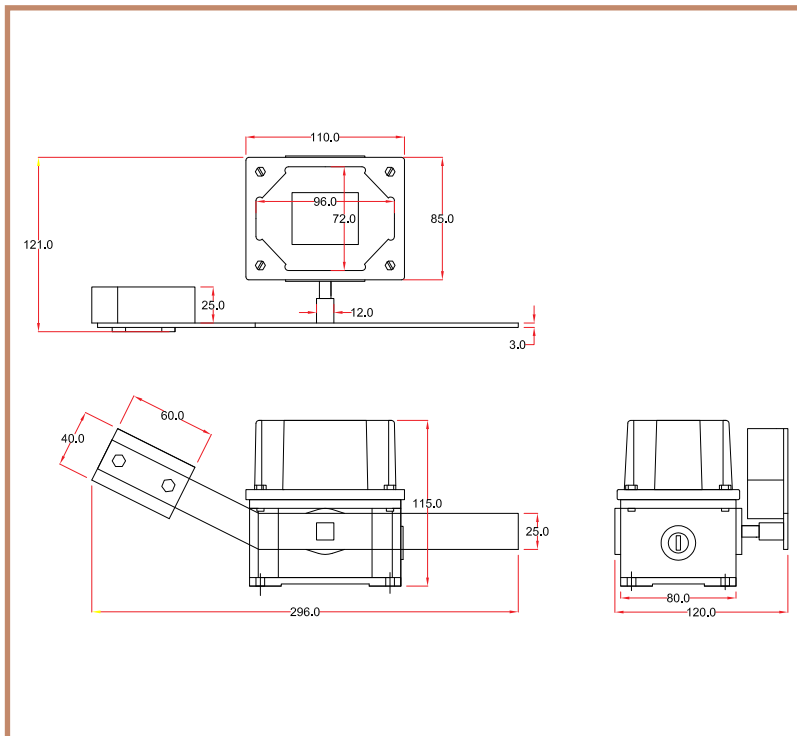

Introduction

Weight Operated Limit Switches are used on control / power circuit of reversing drives so as to limit their rotation / movement within a predetermined position.

Operation:

When the snatch block of the crane reaches its top position the snatch block pushes a plate which is hanging from one end of the lever of the limit switch. Due to the weight placed on the other end of the lever this lever is pushed up. When the lever is pushed up the shaft to which this lever is connected rotates there by rotating the cams which eventually open the contacts