

DEUS - SNT Master Controller (IP-41)

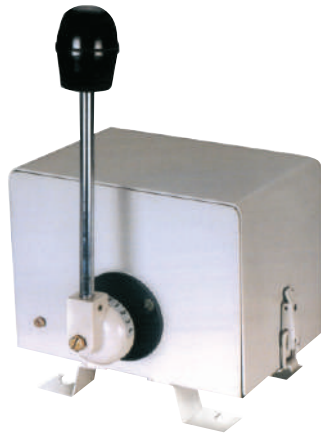

TECHNICAL DATA

Body Material	Steel Sheet Metal
Protection Degree	IP - 41
Mounting Position	Horizontal
Contact Material	Silver Cadmium
Rated Voltage	500 V. A. C.
Thermal Test Current	40Amps.
Cable Entries	2 x 20, 2 x 26 standard conduit
Input Speed	1200 RPM, Maximum
Contacts	Single break
No. Of Contacts	24 maximum
No. Of Steps	6-0-6 maximum
Optional	Spring return/deadman's handle arrangement

Introduction:

Master Controller is housed in enclosure and provided with an easily removable cover with ample area for maintenance. The cam shaft is mounted on bearing bushes on walls of housing. The Cam are made of thermoplast material and fixed on square spindle switch which is moved by a handle. The cams are cut to correspond to the switching program Aluminium die cast Powder Coated Suitable for Hoist-Grab, Mill duty, E. O. T. Cranes and Rolling mill drives.

Steel Sheet Metal

Dimension Details

Type	L	D	No. Of Contacts	No. Of Cable Entries	
				Dia 20	Dia 26
1	135	105	8	2	2
2	195	165	12	2	4
3	245	215	18	2	4
4	305	265	24	2	6

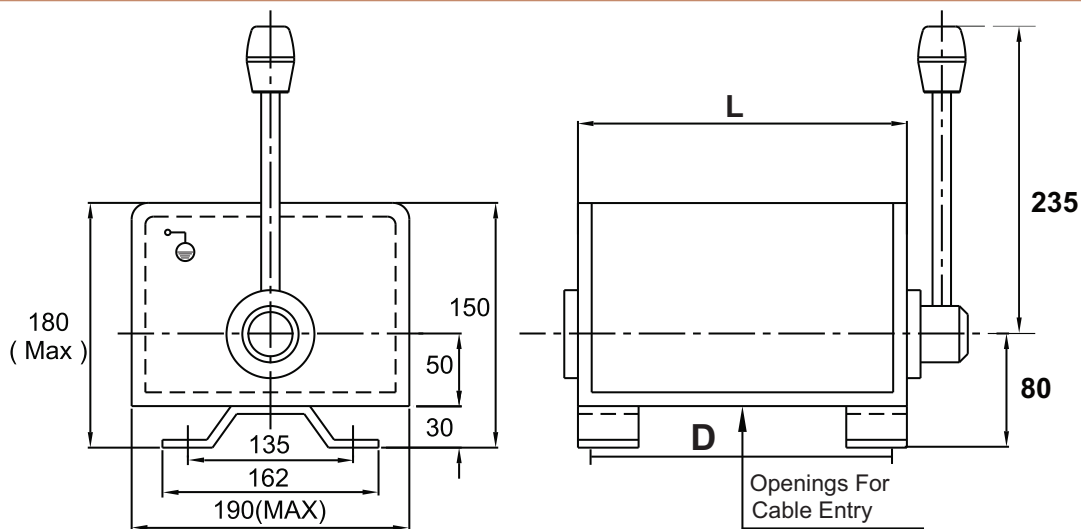

Steel Sheet Metal