

DEUS RRC PVT. LTD.



Leading manufacturer of SNT Radio Remote Control Systems & other Crane Control Equipments.

- Plot No.4319, G.I.D.C, Vatva, Phase IV, Ahmedabad - 382445, Tel: 079-25841148, E-mail:sales@sntrrc.com
- 120, Acharya Ind. Estate, Tejpal Compound, Andheri-kurla Road, Sakinaka, Mumbai-400 072
Tel. : +91 7506507534 / 9821092946 E-mail: mail@sntrrc.com

DEUS - SNT Anti Collision Device



TECHNICAL SPECIFICATION

Supply Voltage	110 / 220v AC
Output Contact rating	5A / 10A at 110v AC
Operating Temperature	Upto 70°C
Sensitivity Adjustment	15 % to 100%
Maximum Sensing Distance	10 meters

GA DRAWING

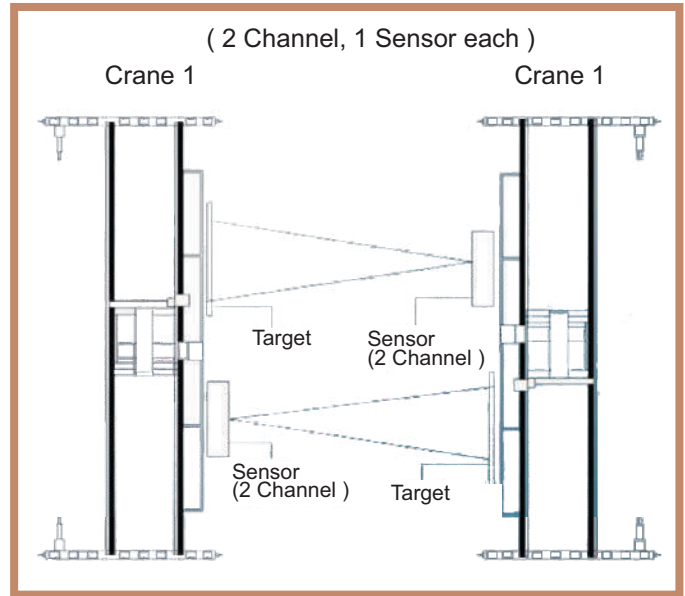

CRANES WITH ANTI-COLLISION SYSTEM

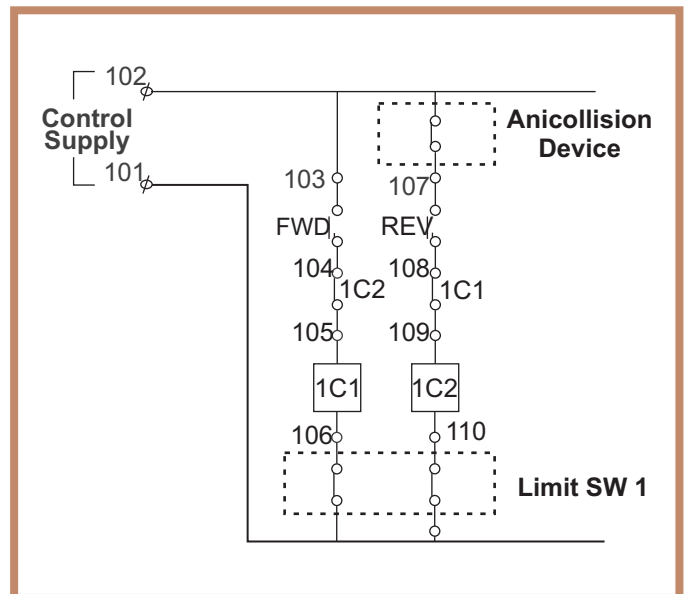

Introduction:

The anti collision System model ACD-201 is safety device to avoid the collision of two electric overhead traveling cranes working on the same rails. The system works on the principle of retro-reflective infrared waves. It consist of an emitter and sensor module and a special reflector. The emitter emits the infrared waves in the direction of the reflector. The reflector reflects these infrared waves back to the sensor. The sensor senses the presence of these reflected infrared waves and activates an alarm signal and stops/reduces the speed of the crane. Thus if the two crane are away from each other then the reflected waves will not reach the sensor and the cranes operate normally. The sensing distance is adjustable between 0 to 3 and 3 to 10 meters. The anti collision system is specially designed for the crane application and is suitable for the continuous duty. Each set consist of an Emitter/sensor module and a reflector.

For one pair of cranes two sets of anti collision systems are required. The typical arrangement for the installation is shown in the adjacent figure.

Installation Procedure

1. Mount the Transmitter/Emitter unit (Control unit) on one crane as shown in the figure.
2. Connect power supply as shown in the connection diagram.
3. Press the laser switch and mark the place for the reflector. Mount the reflector on the second crane.
4. Similarly follow the procedure to mount the control unit and reflector for other crane.
5. Connect the relay contact as shown in the figure.

The anti collision device works like a LT limit switch.